

MONITOR EX MV-150
(for DEL-150 System)

Operation Manual
PLA500.512.105.000 RE



This Manual provides information for service personnel how to perform installation, commissioning and maintenance of the Monitor EX MV-150 (hereinafter referred to as the MV-150).

The MV-150 exploitation is allowed to be used by personnel who has studied this manual, set of exploitation documentation and passed safety training.

The MV-150 monitor is designed for systems for visual monitoring of the values of technological parameters during all types of drilling and workover operations. The EX monitor is used as part of the DEL-150 Drilling and Well Workover Monitoring System (hereinafter referred to as the DEL-150).

Scope of application is explosive zones of premises and outdoor facilities according to Ex-marking. The MV-150 is manufactured in accordance with the requirements of ISO 9001:2015.

In order to exclude the possibility of mechanical damage, violation of electroplating and paint coatings, the rules of storage and transportation of the device should be observed. When studying the rules of operation, it is also necessary to be guided by the technical description and operating instructions of the DEL-150 System.

The MV-150 consists of two metal enclosures connected to each other. A video monitor is installed in the first enclosure. A light-transmitting glass is installed in the wall of the enclosure. In the second enclosure, there are: a power supply board and a control board with electronic mounting elements. On the lower wall of the enclosure there are two cable glands with Ex-marking 1ExdIIcGb. There are holders and grounding signs inside and outside the enclosure.

1. Technical Characteristics

Name of parameter	Value
Diagonal, inches	19
Resolution	1280 x 1024
Brightness, cd/m ²	1600
Contrast	1000:1
Display colors, mln	16.7 (RGB 6 bit, HI_FRC)
Pixel Pitch	0.294 x 0.294
Viewing Angle, °	85 (H), 80 (V)
Processor	Integrated Intel®J1800/2.00GHz Quad core processor
Memory	DDR3 SODIMM 4096 Mb
Network	RTL8111F Gigabit Ethernet
Hard drive	SSD 120 Gb
Operating system	MS Windows 10 Pro
Highlight	WLED
Sensor type	IR
Power supply, VDC	24
Power consumption, max., Wt	10
Ex marking, EAC	1ExdbmbIIBT5Gb
Ingress protection	IP65
Ambient temperature range, °C	-45...+50
Dimensions, mm	370 x 356 x 110
Weight, kg	15
Service life, min., years	8

2. Explosion Safety During Operation

Explosion protection is provided by an explosion-proof enclosure and cast molding (“d” and “m” types of explosion protection).

3. Requirements for Keeping Equipment Specifications that Cause its Explosion Safety

During operation, it is forbidden to break the seals and open the MV-150 enclosure.

When the MV-150 is switched on it is forbidden to connect and disconnect cables, power cable and grounding conductors. In case of malfunctions, it is necessary to turn off the MV-150 and disconnect the power cable from the power source. Then replace the faulty MV-150 with a serviceable one by connecting it according to the documentation.

During operation, check the condition of communication cables periodically. If a violation of the protective layer on the cable lines is detected, replace the damaged cable immediately.

Do not allow sealing violations. If a damage is detected, replace the faulty equipment.

Ensuring explosion safety during operation is according to the safety regulations, applicable to the equipment with which (or as part of which) the equipment is used.



ATTENTION!!! During operation, it is necessary to monitor the equipment status and its cables. In case of any mechanical damage of the equipment or any of the cables connected, further operation is strictly prohibited!

Prohibited actions while the MV-150 operation:

- Cleaning the screen with a dry cloth;
- Using abrasive cleaners;
- Touching the monitor screen with any hard objects;
- Unscrewing the screws and opening the back cover of the monitor;
- Connection a power supply voltage that does not correspond to the characteristics of the monitor;
- Using cables with outside diameter that does not correspond to the monitor's cable gland range 4...9 mm;
- Operation the monitor with the terminal box loosely closed or opened.

4. Installation



NOTIFICATION. Installation and further commissioning of the equipment should be carried out only by qualified specialists.

Before installing the MV-150, it is necessary to make sure that:

- Basic dimensions at the processing facilities correspond to the dimensions of the MV-150 (see Fig. 1);
- Fixing bolts and screws are present;
- There is no damage of the connector insulation;
- There is no external damage of the components;
- There is no damage of the insulation of the signal cable;
- There is no damage of enclosure, cable gland and light-transmitting glass;
- Seal of the terminal box is installed and is in good condition.

The power cable is connected through cable gland to the corresponding port. Switching on occurs automatically when power is applied.

The monitor is connected to the DEL-150 System through a cable gland using a Cat5 communication cable (see Fig. 3). The cable line is connected to the terminals directly in the MV-150's terminal box from one side, and RJ-45 connector is installed on the cable from another side.

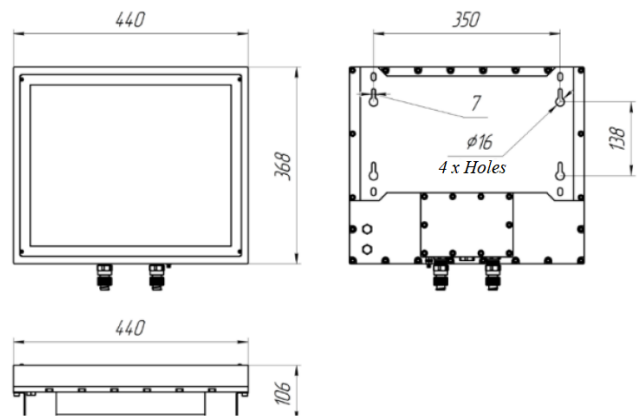

Figure 1. Overall dimensions of the MV-150

Installation requirements

The MV-150 must be mounted in the driller's view, without blocking working area view, at a level and at a distance convenient for information perception.

The MV-150 can be mounted on a bracket in the driller's cabin or can be placed on a suitable vertical surface at a height convenient for viewing. The following factors should be considered:

- Providing easy access to the monitor for periodic maintenance work;
- Installation on a hard surface where there are no vibrations.

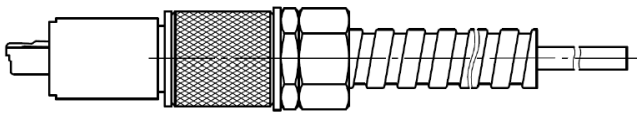

Figure 2. The MV-150 installation example in the driller's cabin

Electrical connection

The electrical connection is performed in the following order:

1. Open the terminal box on the MV-150's back side using a 6 mm hex key (See Fig.4);
2. Run power cable to the monitor through the cable gland #1 and connect it to the terminals according to the diagram (see Fig. 5);
3. Run communication cable to the monitor through the cable gland #2 and connect it to the terminals according to the diagram (see Fig. 5);
4. Close and lock the terminal box's cover;
5. Connect a grounding or zero protective conductor to the monitor enclosure;
6. Connect the monitor to the MU-150E Control Module of the DEL-150 System using a communication cable;
7. Turn on the MV-150 monitor.



	Com.
White-Orange	1
Orange	2
White-Green	3
Blue	4
White-Blue	5
Green	6
White-Brown	7
Brown	8

RJ45 5E 8P8C

Figure 3. Communication Cable

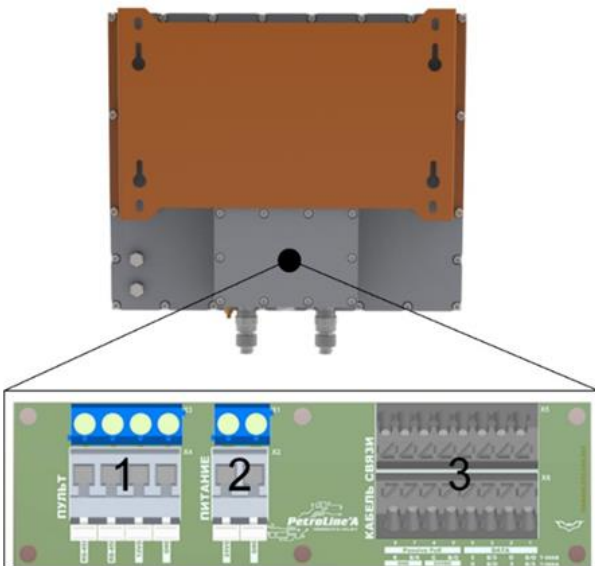

1. USB terminal;
2. Power supply terminal;
3. Communication cable terminal

Figure 4. Terminal box

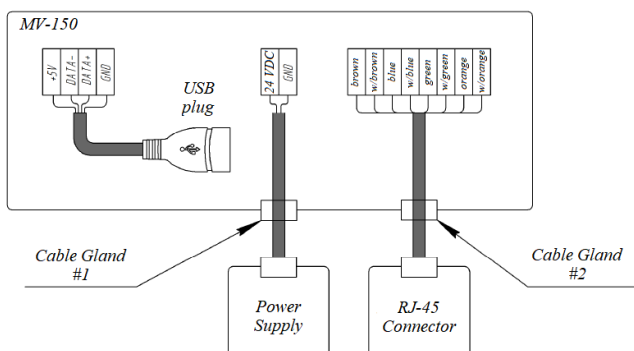



Figure 5. The MV-150 connections

5. The MV-150 Setup for Data Synchronization with MU-150E Control Module

To synchronize the MV-150 with the MU-150E, it is necessary:

- SCADA software version v1.07 and below – set the MU-150E's IP-address in the App.ini file located in the "Touch" Rev.01

folder of software (see Fig. 6) and save the file with the changes made;

- SCADA software version v1.10 and higher – left-click the button, located at the bottom of the screen  and set the required IP-address accordingly (see Fig. 7).

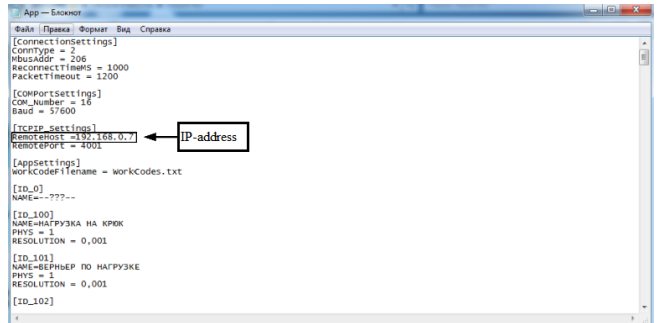

Figure 6. System parameters editing window (for software versions v1.07 and below)

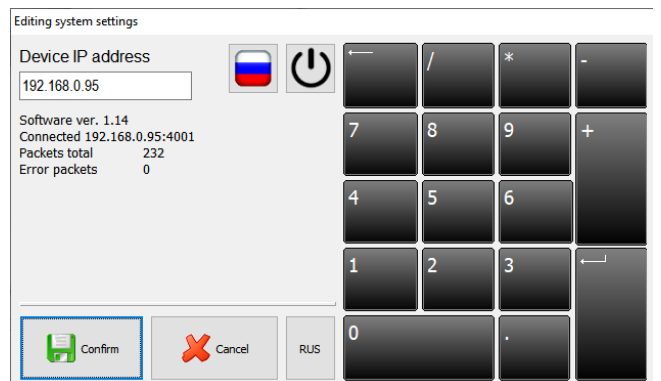

Figure 7. System parameters editing window (for software versions v1.10 and higher)

6. The MV-150 Screen Operation

The Driller Monitor software is automatically started after the MV-150 is turned on (see Fig. 8, 9). Screen contains fields with the parameters selected during the last startup. If there is a network connection, the monitor connects and synchronizes with the data stored in the MU-150 Control Module connected to this network.

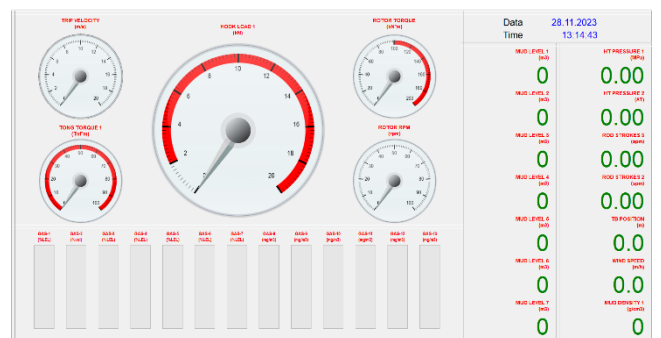

Figure 8. Driller Monitor software's screen example (Monitor 1)

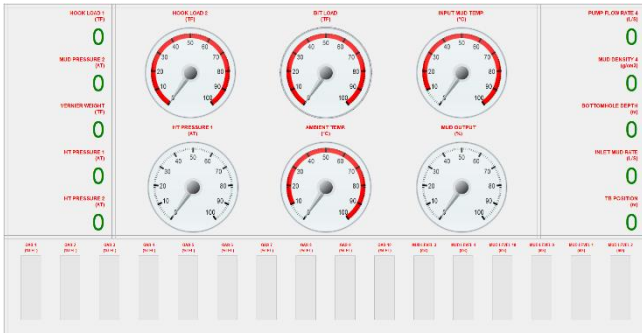

Figure 9. Driller Monitor software’s screen example (Monitor 2)

Drilling parameters adjustment is carried out by opening the "Measure parameter" dialog box in the following order:

1. Select the required parameter name from the list (see Fig.10);
2. Select the required units of measurement, max. and min. scale values if needed;
3. Save the changes.

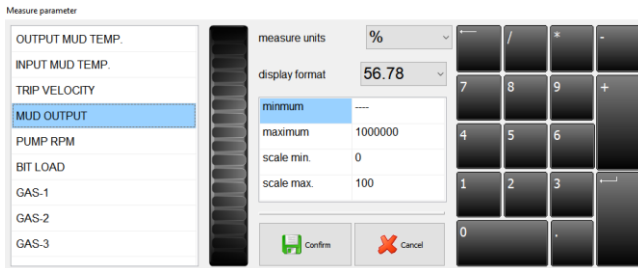

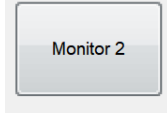
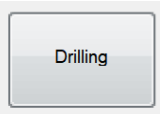
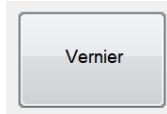
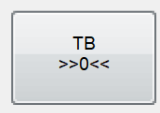
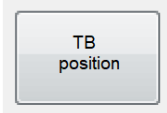

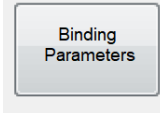
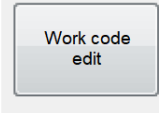







Figure 10. Parameter adjustment dialog box

The Driller Monitor software includes the following buttons:

 	Monitors switching over
 	On/off "Vernier" and "Drilling" modes
  	Zeroing of travelling block position Setting of travelling block position value Setting of hole depth value

 	Binding parameters setup (number of well, crew, etc.) Work code setup
 Successful Connection with the MU-150E	System parameters editing
 Attempting of Connection with the MU-150E	
 Connection Lost with the MU-150E	
	Changing the screen brightness
	Locking the screen

7. Troubleshooting

If connection with the MV-150 is lost, the message "Connection attempt" will be displayed (see Fig. 11).

```

Software ver. 1.14
Connection attempt... 192.168.0.96:4001
Packets total      65
Error packets     0
  
```

Figure 11. Connection dialog box

In case of loss of communication with the MV-150 it is necessary to carry out actions in the following order:

1. Check the integrity of the communication cable;
2. Replace the cable;
3. Check the MV-150 and the MU-150E network settings.

8. Marking and Packaging

The MV-150's nameplate includes the following components (see Fig.12):

1. Trademark or name of manufacturer;
2. Part number;
3. Name and model;
4. Serial number;
5. Manufacturing year;
6. Explosion protection marking together with certificate number;
7. Technical characteristics.

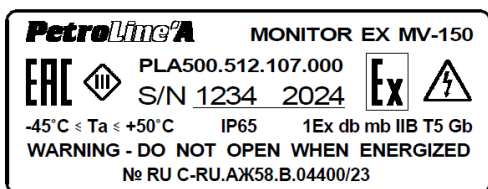

Figure 12. Example of the MV-150 marking

Other data required by regulatory and technical documentation may also be reflected on the nameplate.

Boxes made of plywood with metal handles for carrying are used to transport the MV-150 as part of the DEL-150 System.

9. List of Components

Full completeness is indicated in the passport for equipment released by manufacturer.

10. Repair

Repair of the MV-150 is carried out at the manufacturer or at a specialized authorized service center.



NOTIFICATION. Absence of repair records in the passport (section "Repair Records") ENTAILS VIOLATION OF THE OPERATION RULES, and the manufacturer has the right to withdraw from warranty obligations

11. Storage

The equipment requires careful handling, storage in dry, clean rooms with a constant temperature from +10°C to +35°C as an optimum range and a relative humidity of no more than 80%. Daily temperature fluctuations should not exceed 5°C.

The long-term storage requires conservation, according to the requirements of the equipment conservation instructions.

The equipment arriving at the warehouses in the manufacturer's containers are not unpacked, packed on flat pallets and stacked or in the cells of the racks.

Factory-sealed devices are not allowed to be opened in warehouses.

Small devices and devices arriving in individual packaging are stored in box pallets with installation in a stack. Devices and components without individual packaging should be stored in shelving cells no more than 3 rows in height with the use of cushioning materials between them.

Small devices and products arriving without packaging can be stored in small-cell racks and cabinets, while devices or products of the same type should be stored in one cell.



NOTIFICATION. Absence of storage records in the passport (section "Storage Records") ENTAILS VIOLATION OF THE OPERATION RULES, and the manufacturer has the right to withdraw from warranty obligations

12. Transportation

Transportation of the equipment is allowed by all types of closed transport. The MV-150 in a package for transportation allows the impact of transport shaking with an acceleration of 30 m/s² with a frequency of 100 beats per minute or 1500 beats with that acceleration.

13. Disposal

The MV-150 is disposed of in accordance with the requirements and norms applicable in the oil and gas industry.

14. Warranty Obligations

The warranty period is 12 months from the date of sale.

A full description of the warranty obligations is described in the equipment passport.

RPE Petroline-A LLC
Address: 53A Lermontova St., Naberezhnye Chelny,
Republic of Tatarstan, Russian Federation, 423801
Postal address: P.O. Box 23, 423801
Phone/Fax: +7 (8552) 535-535, 71-74-61
main@pla.ru, www.pla.ru