

## ENCODER DPS-140

Operation Manual  
PLA140.207.000.000 RE



This Manual provides information for service personnel how to perform installation, commissioning and maintenance of the Encoder DPS-140 (hereinafter referred to as the DPS-140).

The DPS-140 exploitation is allowed to be used by personnel who has studied this manual, set of exploitation documentation and passed safety training.

The DPS-140 is intended to control rig's drawworks revolutions for the following drilling parameters calculation: BLOCK HEIGHT, TRIP VELOCITY, ROP, HOLE DEPTH, BIT POSITION. This device is made as part of the DEL-150 Drilling and Well Workover Monitoring System (hereinafter referred to as the DEL-150). The DPS-140(IVR) configuration (Mud Flow Sensor) is intended to control parameter MUD OUTPUT.

Scope of application is explosive zones of premises and outdoor facilities according to Ex-marking. The DPS-140 is manufactured in accordance with the requirements of ISO 9001:2015.

In order to exclude the possibility of mechanical damage, violation of electroplating and paint coatings, the rules of storage and transportation of the device should be observed. When studying the rules of operation, it is also necessary to be guided by the technical description and operating instructions of the DEL-150 System.

### 1. Technical Characteristics

Name of parameter	Value
Minimum measurement limit, m	0.01*
Pulses per revolution of the DPS-140(P)	72
Pulses per revolution of the DPS-140(A)	4096

Pulses per revolution of the DPS - 140(V)	36
Pulses per revolution of the DPS-140(I)	Depends on the number of triggers
Pulses per revolution of the DPS-140(IVR)	n/a
Drawworks shaft outside diameter for installation of the DPS-140(P), mm	25...40
Output signal	Digital
Communication protocol	Modbus
Power supply range, VDC	12...18
Ex marking, EAC	1ExibIIBT5Gb
Ex marking, ATEX	II2GExibIIBT5Gb
Ingress protection	IP66
Ambient temperature range, °C	-45...+65
Dimensions of the DPS-140(P), mm	Ø150 x 52
Dimensions of DPS-140(A), mm	Ø62 x 145
Dimensions of DPS-140(V), mm	128 x 62 x 62
Dimensions of DPS-140(I), mm	80 x 75 x 55
Dimensions of DPS-140(IVR), mm	400 x 80 x 400
DPS-140(P, V) weight, max., kg	1.5
DPS-140(A) weight, max., kg	2
DPS-140(I) weight, max., kg	1
DPS-140(IVR) weight, max., kg	3.3
Service life, min., years	10

\* except DPS-140(I) and DPS-140(IVR)

### 2. Explosion Safety During Operation

Explosion protection is provided by an intrinsically safe electrical circuit ("i" type of explosion protection).

### 3. Requirements for Keeping Equipment Specifications that Cause its Explosion Safety

During operation, it is forbidden to break the seals and open the DPS-140 enclosure.

When the MU-150 / MU-150E / MK-140 unit of the DEL-150 System is switched on, it is forbidden to connect and disconnect cables, power cable and grounding conductors. In case of malfunctions, it is necessary to turn off the MU-150 /

MU-150E / MK-140 unit and disconnect the power cable from the power source. Then replace the faulty DPS-140 with a serviceable one by connecting it according to the documentation (operation manual for the DEL-150).

During operation, check the condition of communication cables periodically. If a violation of the protective layer on the cable lines is detected, replace the damaged cable immediately.

Do not allow sealing violations. If a damage is detected, replace the faulty equipment.

Ensuring explosion safety during operation is according to the safety regulations, applicable to the equipment with which (or as part of which) the equipment is used.



**ATTENTION!!! During operation, it is necessary to monitor the equipment status and its cables. In case of any mechanical damage of the equipment or any of the cables connected, further operation is strictly prohibited!**

#### 4. Installation



**NOTIFICATION. Installation and further commissioning of the equipment should be carried out only by qualified specialists.**

Before installing the DPS-140, it is necessary to make sure that:

- Basic dimensions at the processing facilities correspond to the dimensions of the DPS-140 (see Appendix A);
- Fixing bolts and screws are present;
- There is no damage of the connector insulation;
- There is no external damage of the components;
- There is no damage of the insulation of the signal cable.

Disregard of this instruction may lead to a serious failure of the DPS-140.

Several mounting options are provided for the DPS-140. The choice of option depends on the type of drawworks, conditions and availability of space for installation of equipment. The method of mounting on similar drawworks may differ.



**ATTENTION!!! For safety, the DPS-140 should be mounted when the drawworks is stopped**

The installation place of the DPS-140 (P, V) can be the rotary drawworks drum shaft from the swivel side. To prevent the DPS-140 (P, V) rotation together with the drawworks drum shaft, a stretching in the form of a metal plate or a rope 2...3 mm is used. The stretch can also consist of a lock pin and a ball point. To install the DPS-140 (P, V), it is necessary to fill in the data indicated in Fig. 1, 2.

In the case of constant rotation of drawworks drum shaft from the swivel, the DPS-140 (A, V, P) installation is impossible. In this case, the DPS-140(I) with inductive position sensors (e.g. VBI sensors) is installed (see Appendix A, Fig. 18, 20, 21).

Inductive proximity switches have a sensing element in the form of an inductor with a magnetic circuit open towards the active surface. An electromagnetic field is formed in front of the active surface of the sensor. When a metal object (trigger) is inserted into this field, the cross point of the sensor is

switched. Triggers can be located on the brake drawworks drum or on the drum on the side of the cable winding.

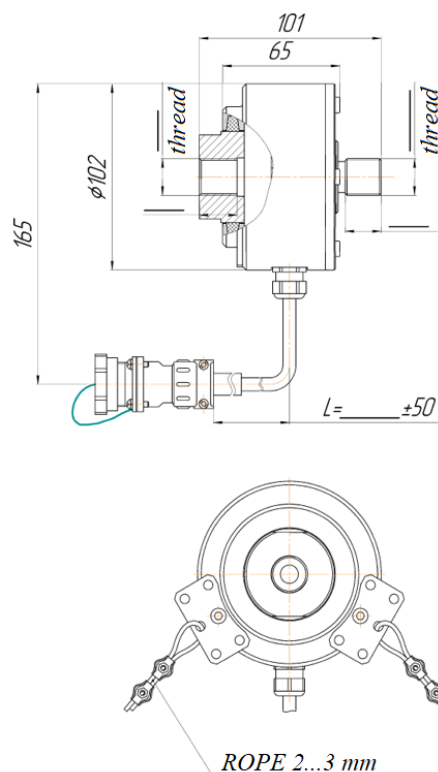

**Figure 1. The DPS-140(V) installation example (threaded installation)**

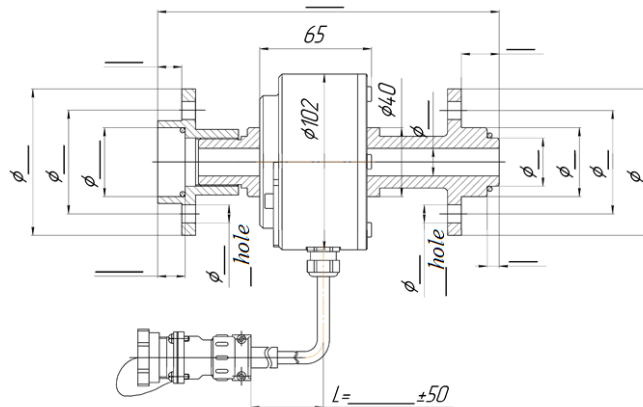
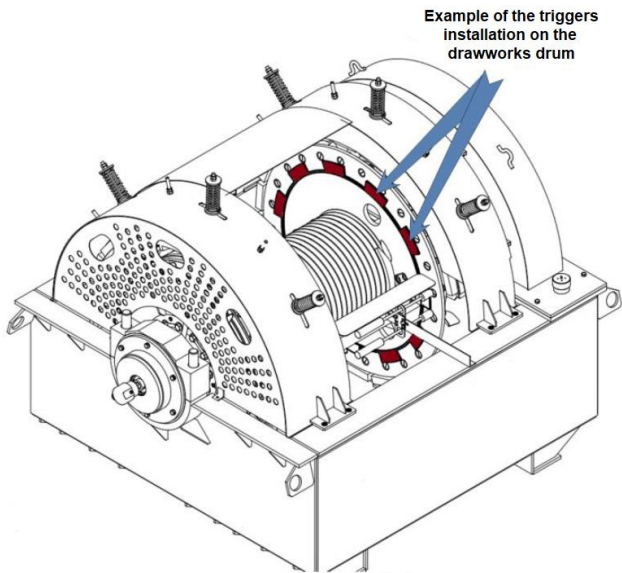

**Figure 2. The DPS-140(V) installation example (flange installation)**

Triggers for an inductive sensor should be installed considering the following:

- Location along the drawworks drum circumference through an equal distance, but not less than the length of the trigger (see Fig.3);
- The distance of the VBI from the triggers is not more than 5 mm. (see Fig. 4);
- The distance between the VBI should be such that both VBI overlap simultaneously with the trigger (see Fig. 4).

For the TRIP VELOCITY parameter, the presence of the DPS-140(I) with one VBI is sufficient. The DPS-140(I) with two VBI must be used to calculate the parameters BLOCK HEIGHT, HOLE DEPTH, ROP, BIT POSITION.



**Figure 3. Example of the triggers installation on the drawworks**

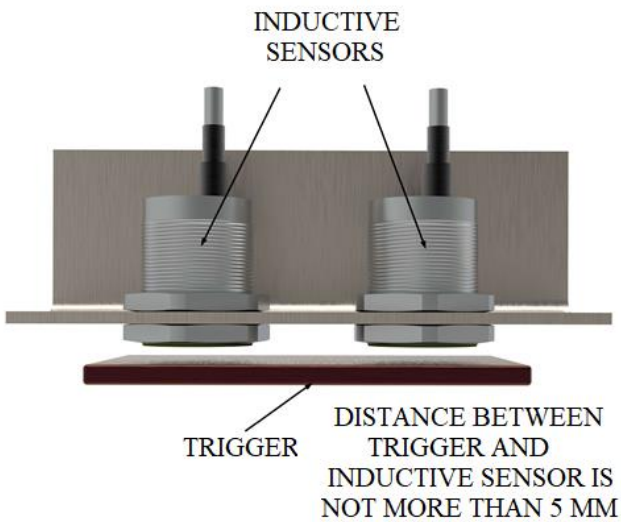
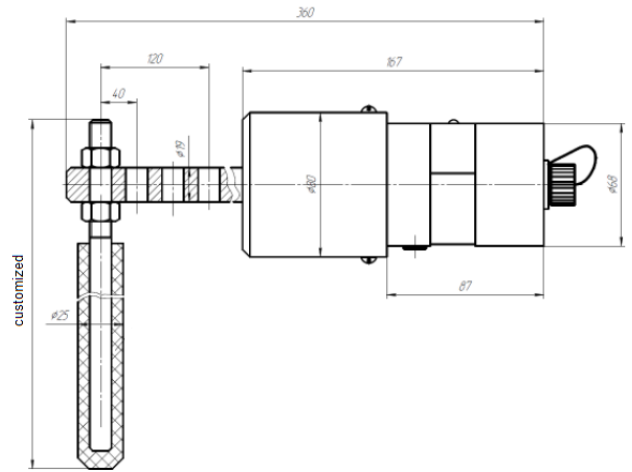

**Figure 4. Inductive proximity sensors installation**

Installation of the DPS-140(A) sensor with an asterisk under the driven chain performs with the following procedure:

1. Installation of the sensor pad;
2. Installation of the sensor in such a way that the sensor shaft is located parallel to the drawworks shaft with the possibility of adjusting the chain tension;
3. Installation of the chain, pre-tightening the mounting bolts, checking the rotation. Reinstall if necessary;
4. Final tightening of the sensor mounting bolts on the base;
5. Connection of the sensor cable;
6. Check of the parameter in the list on the Control Module display;
7. Calibration of the TRIP VELOCITY parameter.

Installation of the DPS-140(IVR) sensor depends on the requirements and can be performed on the open or closed part of the return flow line according to its overall dimensions (See Fig.5).



**Figure 5. The DPS-140(IVR) overall dimensions**

In case of power failure of the DPS- 140(P), DPS-140(I), DPS-140 (V) a power supply is used (in agreement with the Customer) (see Fig. 6).

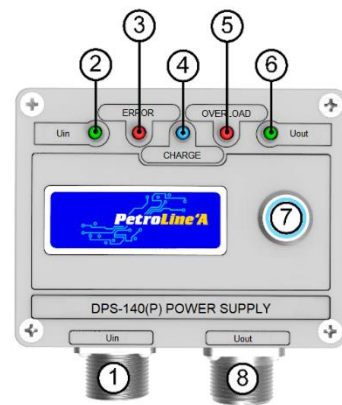

1. Connector for connecting the communication cable to the MU-150 / MU-150E / MK-140 unit of the DEL-150 System (RS-485);
2. Input voltage LED;
3. Battery charge error LED;
4. Battery charge LED;
5. LED over-current in the circuit (more than 100 mA)
6. LED output voltage;
7. Power button;
8. Connector for connecting the communication cable to the DPS-140 sensor.

**Figure 6. Power supply for the DPS-140**

### 5. External Electrical Connections Installation

Connecting the DPS-140 to the MU-150 / MU-150E / MK-140 unit of the DEL-150 System, use the SHR20/SHR20 universal commutation cable from the supplied package (see Fig. 7).

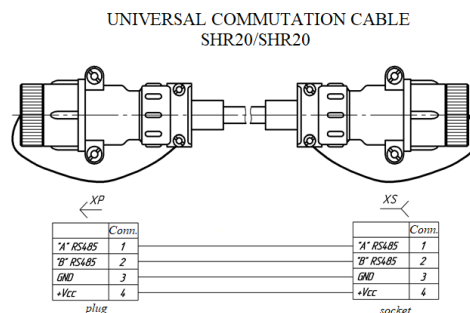

**Figure 7. SHR20/SHR20 universal commutation cable**

The cable from the DPS-140 is connected to any of the connectors of the MU-150 / MU-150E / MK-140 unit marked "RS-485" / "Sensor" (see Fig. 8).

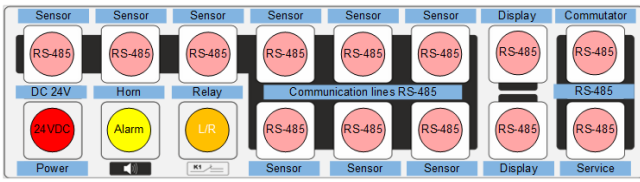

Figure 8. The MU-150 / MU-150E / MK-140 unit's connectors "RS-485" / "Sensor" for the DPS-140 connection

## 6. The DPS-140 Functional Test

For functional test of the DPS-140 it is necessary to connect the sensor to the MU-150 / MU-150E / MK-140 unit, to turn power on and to make sure that the parameter TRIP VELOCITY is displayed on the MU-150 / MU-150E EL screen (see Fig. 9).



Figure 9. Readings on the Control Module display in operating mode

## 7. Readings Issues

If the connection with the DPS-140 is lost, the symbol "----" opposite the parameter TRIP VELOCITY is displayed on the MU-150 / MU-150E EL screen (see Fig. 10).



Figure 10. Readings in case of loss of communication with the DPS-140

In case of loss of communication with the DPS-140 it is necessary to carry out actions in the following order:

1. Checking of the integrity of the commutation cable;
2. Reconnection of the DPS-140 cable to the free connector of the MU-150 / MU-150E / MK-140 unit marked "RS-485" / "Sensor";
3. Checking of the presence of the parameter in the related menu's list of the Control Module;
4. Replacement of the cable;
5. Checking of the presence of the parameter in the related menu's list of the Control Module;
6. Replacement of the DPS-140;
7. Checking of the presence of the parameter in the related menu's list of the Control Module.

## 8. Setting of the DPS-140

When the sensor installation is completed, it is necessary to

turn on the MU-150 Control Module and to enter the setting mode using the MU-150's keyboard (see Fig. 11).

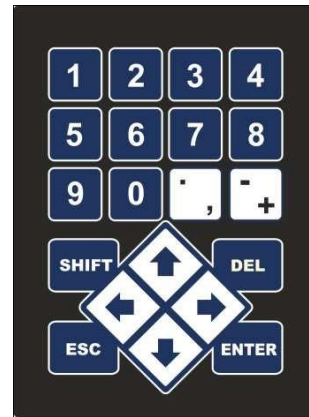

Figure 11. The MU-150 Control Module keyboard







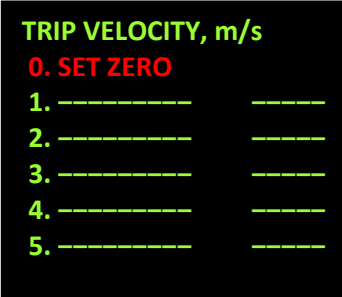

Proceed in the following order to reach out required parameter:

1. Unblock the keyboard by pressing **SHIFT** + **ENTER** simultaneously;
2. Enter OPERATING PARAMETERS menu by pressing **SHIFT** + **3** simultaneously;
3. Use **↓**, **↑** and **ENTER** to select required parameter. To return to the previous menu, use **ESC**.

### 8.1. Setting of TRIP VELOCITY Parameter

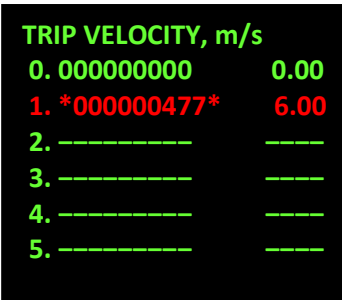
<b>ENTER</b>	<b>ROTARY RPM</b> <b>TRIP VELOCITY</b> <b>BLOCK HEIGHT</b> <b>HOLE DEPTH</b>
Set the required maximum and minimum values	<b>TRIP VELOCITY, m/s</b> <b>MAX 0003.0</b> <b>MIN -003.0</b> <b>SENSOR CALIBRATION</b>
Proceed for a sensor calibration mode. Press <b>SHIFT</b> + <b>ENTER</b>	<b>TRIP VELOCITY, m/s</b> <b>MAX 0003.0</b> <b>MIN -003.0</b> <b>SENSOR CALIBRATION</b>

## 8.2. Calibration of TRIP VELOCITY Parameter

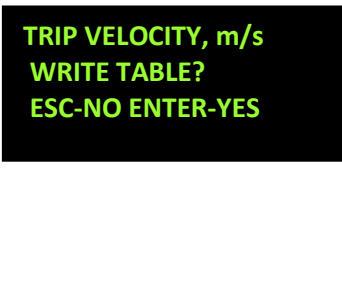
<p>Lower the travelling block to the lowest position. Press</p> 	
<p>Go to the line below by clicking</p>  <p>Raise the travelling block to an accurately measured height (for example, 6.00 m). Press</p>  <p>Enter the height value and press again</p> 	
<p>Repeat the steps by lifting the travelling block to different heights until the table is filled in</p>	
<p>When the calibration is completed, press</p>  then  <p>to record the calibration table</p>	



**NOTIFICATION.** If the pulse values are negative during calibration at several points (see Fig. 12 as an example), it is necessary to connect to the DPS-140 sensor by USB-RS485 converter and using the MBARW service software change the value of register #10 from "0" to "1" (See Fig. 13). Press the "Write" button then (applicable for the DPS-140 sensor with the firmware version 1.48 and above).

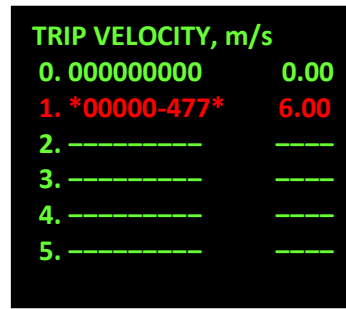

Figure 12. Negative pulse value

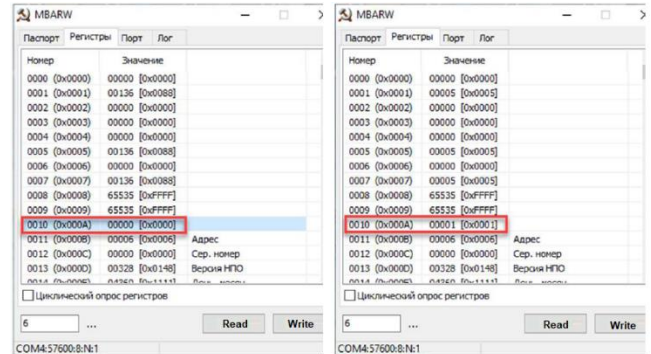







Figure 13. MBARW service software interface

## 8.3. Setting of BLOCK HEIGHT Parameter

	
<p>Set the required maximum value (the travelling block position of above the rotary table in meters)</p>	
<p>Reset to zero at the bottom point (if necessary)</p>	
<p>The OFFSET option is provided for coiled tubing units</p>	

#### 8.4. Setting of HOLE DEPTH Parameter

	<b>ROTARY TORQUE</b> <b>ROTARY RPM</b> <b>TRIP VELOCITY</b> <b>BLOCK HEIGHT</b> <b>HOLE DEPTH</b>
Enable HOLE DEPTH calculation mode  <b>AUTO*</b> – calculation is performed automatically according to the entered settings  <b>MANUAL**</b> – calculation is performed in manual mode	<b>HOLE DEPTH, m</b> <b>MODE</b> <span style="float: right;"><b>OFF</b></span> <b>HOLE DEPTH</b> <span style="float: right;"><b>000.0</b></span> <b>PRESS.THR,at</b> <span style="float: right;"><b>16.0</b></span> <b>W.FILTER N</b> <span style="float: right;"><b>17</b></span> <b>WOB THR1, tf</b> <span style="float: right;"><b>02.0</b></span> <b>WOB THR2, tf</b> <span style="float: right;"><b>7.0</b></span> <b>VELOCITY THR,m/s</b> <span style="float: right;"><b>0.13</b></span> <b>STAND LENGTH,m</b> <span style="float: right;"><b>0.00</b></span>

**\*AUTO mode.** When working, the parameters HOOK LOAD, MUD PRESSURE, BLOCK HEIGHT and TRIP VELOCITY are used.

The beginning of drilling is determined by manifold pressure. When the pressure (MUD PRESSURE IN parameter) passes the limit of 16 atm. (PRESS.THR), the initial HOOK LOAD is stored, from which the WOB will be calculated further. While the pressure is above 16 atm. (PRESS.THR), the WOB parameter is calculated (initial HOOK LOAD minus current HOOK LOAD) if the WOB is higher than the limit (WOB THR1 / WOB THR2), and the TRIP VELOCITY does not exceed 0.13 m/s, it is determined by the System that the bit has reached against the depth and the depth increases depending on the travelling block movements. Thus, at each step, the algorithm calculates the difference between the previous BLOCK HEIGHT and the current BLOCK HEIGHT and if all conditions are met (MUD PRESSURE IN is greater than the limit, WOB is greater than the limit, the current BLOCK HEIGHT is less than the previous BLOCK HEIGHT, TRIP VELOCITY is less than limit as well), the algorithm adds this difference to the HOLE DEPTH parameter. The discreteness of the algorithm is ~100 ms.

HOLE DEPTH can be set initially or edited.

Parameters affecting the algorithm for calculating the HOLE DEPTH:

- **PRESS.THR,at** – manifold pressure limit;
- **W.FILTER N** – WOB parameter filter;
- **WOB THR1, tf** – the first limit of the WOB. It is used as long as the current HOOK LOAD is less than 10 tf;
- **WOB THR2, tf** – the second limit of the WOB. It is used as long as the current HOOK LOAD is more than 10 tf;
- **VELOCITY THR,m/s** – trip velocity limit;
- **STAND LENGTH,m** – the average length of the pipe. If this value is set, the algorithm will automatically correct the HOLE DEPTH by the value of STAND LENGTH at each

make-up. If the value is set to "0", then this parameter is not used and the difference between the BLOCK HEIGHT is used for HOLE DEPTH calculation.

**\*\*MANUAL mode.** In manual mode, all calculations remain the same as in automatic mode, but instead of the manifold pressure, a signal from the "DRILL" button of the pushbutton

panel is used (see Fig. 14) or by pressing  on the MU-150 Control Module.

The HOLE DEPTH is calculated only when the drill mode is turned on.



Figure 14. Pushbutton panel

It is required to turn on "DRILL" button every time after make-up before drilling in manual mode and to turn off after each stand drilling.

#### 8.5. Setting of BIT POSITION Parameter

BIT POSITION parameter is calculated. The calculation uses the readings of two parameters HOOK LOAD and BLOCK HEIGHT.

When HOOK LOAD is greater than the limit, then it is determined that the drillstring is moving and BIT POSITION parameter is incremented depending on the travelling block movements. The limit value of HOOK LOAD is set through the DEL-150's Control Module menu. It is set 0.7 tf by default.

	<b>ROTARY RPM</b> <b>TRIP VELOCITY</b> <b>BLOCK HEIGHT</b> <b>HOLE DEPTH</b> <b>BIT POSITION</b>
Enable bit position calculation mode	<b>BIT POSITION, m</b> <b>MODE</b> <span style="float: right;"><b>OFF</b></span> <b>HL THRES,tf</b> <span style="float: right;"><b>0.70</b></span> <b>ADJUSTMENT</b> <span style="float: right;"><b>0000.0</b></span>

Set the lower limit value of HOOK LOAD parameter	<pre> BIT POSITION, m MODE                OFF HL THRES,tf        0.70 ADJUSTMENT         0000.0 </pre>
Correct the current value of BIT POSITION if needed	<pre> BIT POSITION, m MODE                OFF HL THRES,tf        0.70 ADJUSTMENT         0000.0 </pre>

### 8.6. ROP Parameter

The ROP parameter is calculated. Every 20 seconds, the difference between the previous HOLE DEPTH and the current one is calculated, and differentiated by time.

### 8.7. Setting of ROPE WEAR Parameter



**NOTIFICATION. ROPE WEAR parameter has been added since the firmware version of the Control Module v11.03**

ROPE WEAR is calculated by multiplying of distance travelled by travelling block by the current hook load and summarizing it with the previous accumulated value.



**NOTIFICATION. The physical wearing of rig's rope will be affected by the rig's lines strung value also. Larger lines strung number leads to higher rope wearing considering the same ROPE WEAR parameter in the DEL-150 System**

The required parameters for ROPE WEAR calculation are HOOK LOAD, BLOCK HEIGHT or TRIP VELOCITY.

ROPE WEAR parameter is displayed also in the Drilling and Well Workover Monitoring Software (item "Details"). Identification of ROPE WEAR parameter to distinct rope occurs by the serial number, which is set in the settings of the DEL-150's Control Module.

	<pre> MUD PRESS.IN4 ROPE WEAR SKR COILED TUBING </pre>
Enable ROPE WEAR calculation mode	<pre> ROPE WEAR, tf*km MODE                OFF VALUE              000000 S/N MAX                ---- </pre>

Correct the current value of ROPE WEAR if needed	<pre> ROPE WEAR, tf*km MODE                OFF VALUE              000000 S/N MAX                ---- </pre>
Set rope serial number	<pre> ROPE WEAR, tf*km MODE                OFF VALUE              000000 S/N MAX                ---- </pre>
Set the required maximum value	<pre> ROPE WEAR, tf*km MODE                OFF VALUE              000000 S/N MAX                ---- </pre>

### 9. List of Critical Failures and Possible Issues in Maintenance Leading to Equipment Failures and Actions to Prevent these Failures (troubleshooting)

Incorrect power supply can lead to equipment failure.

Incorrect set maximum values for parameters can lead to incorrect operation of the external controlled equipment if the maximum level for the controlled parameter is exceeded.

A short circuit or a break circuit in the power and communication lines of the sensor, may cause loss of communication with the sensor with the following failures: lack of parameter data, symbols "???" or "----" instead of parameter data, lack of data on other parameters.

In case of failure of the sensor or Control Module, it is necessary to check the equipment technical condition according to the Clause #8 of this Operation Manual. If troubleshooting did not lead to proper operation, it is necessary to stop operation and replace with obviously serviceable equipment. Defective equipment should be sent for repair to the manufacturer or to the specialized authorized service center.

In case of failures that can lead to emergency situations, it is necessary to replace the equipment that has failed. If necessary, disable additional external devices.

### 10. Maintenance Procedure

Maintenance is carried out in the following order:

1. Cleaning the sensor's enclosure from contamination;
2. Checking the safety of seals (if available);
3. Checking the presence and strength of the mounting components;
4. Cleaning of connectors and terminals from contamination;
5. Checking for the absence of visible mechanical damages;
6. Replacement and (or) repair of damaged cable products;
7. Replacement of damaged connectors.

The contacts of the connector should be washed with an alcohol-gasoline mixture (need 3 ml.) using a soft brush. Connectors after cleaning and drying should be treated with Vaseline or similar lubricant. It is recommended to treat the threads on the connectors with graphite grease.



**NOTIFICATION. Absence of maintenance records in the passport (section "Maintenance Records") ENTAILS VIOLATION OF THE OPERATION RULES, and the manufacturer has the right to withdraw from warranty obligations**

### 11. Limit Conditions Parameters

In case of severe mechanical damage, leakproofness violations, seals violations, heating of parts to unacceptable temperatures, supply of unacceptable currents and voltages, change of calibration data, further use is unacceptable or impractical, or restoration of its serviceable or operable condition is impossible or impractical.

### 12. Marking and Packaging

The DPS-140's nameplate includes the following components (see Fig.15):

1. Trademark or name of manufacturer;
2. Part number;
3. Name and model;
4. Serial number;
5. Manufacturing year;
6. Explosion protection marking together with certificate number;
7. Technical characteristics.

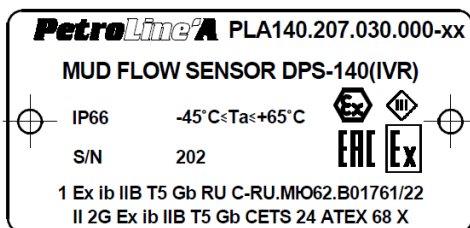
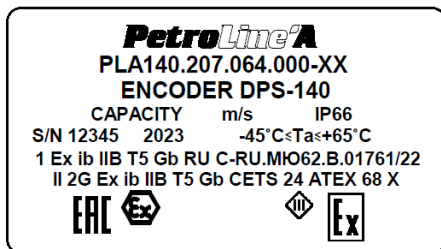

**Figure 15. Examples of the DPS-140 marking**

Other data required by regulatory and technical documentation may also be reflected on the nameplate.

Boxes made of plywood with metal handles for carrying are used to transport the DPS-140 as part of the DEL-150 System.

### 13. List of Components

Full completeness is indicated in the passport for equipment released by manufacturer.

### 14. Repair

Repair of the DPS-140 is carried out at the manufacturer or at a specialized authorized service center.



**NOTIFICATION. Absence of repair records in the passport (section "Repair Records") ENTAILS VIOLATION OF THE OPERATION RULES, and the manufacturer has the right to withdraw from warranty obligations**

### 15. Storage

The equipment requires careful handling, storage in dry, clean rooms with a constant temperature from -50°C to +50°C and a relative humidity of no more than 80%.

The long-term storage requires conservation, according to the requirements of the equipment conservation instructions. The equipment arriving at the warehouses in the manufacturer's containers are not unpacked, packed on flat pallets and stacked or in the cells of the racks.

Factory-sealed devices are not allowed to be opened in warehouses.

Small devices and devices arriving in individual packaging are stored in box pallets with installation in a stack.

Devices and components without individual packaging should be stored in shelving cells no more than 3 rows in height with the use of cushioning materials between them.

Small devices and products arriving without packaging can be stored in small-cell racks and cabinets, while devices or products of the same type should be stored in one cell.



**NOTIFICATION. Absence of storage records in the passport (section "Storage Records") ENTAILS VIOLATION OF THE OPERATION RULES, and the manufacturer has the right to withdraw from warranty obligations**

### 16. Transportation

Transportation of the equipment is allowed by all types of closed transport. The DPS-140 in a package for transportation allows the impact of transport shaking with an acceleration of 30 m/s<sup>2</sup> with a frequency of 100 beats per minute or 1500 beats with that acceleration.

### 17. Disposal

The DPS-140 is disposed of in accordance with the requirements and norms applicable in the oil and gas industry.

### 18. Warranty Obligations

The warranty period is 12 months from the date of sale.

A full description of the warranty obligations is described in the equipment passport.



**Appendix A. Overall Drawings**

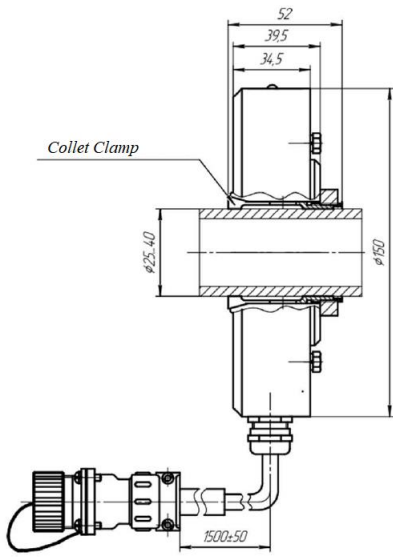

**Figure 16. Overall drawing of the DPS-140(P)**

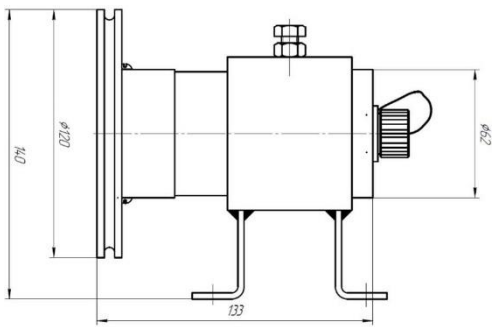

**Figure 17. Overall drawing of the DPS-140(A) with sheave wheel**

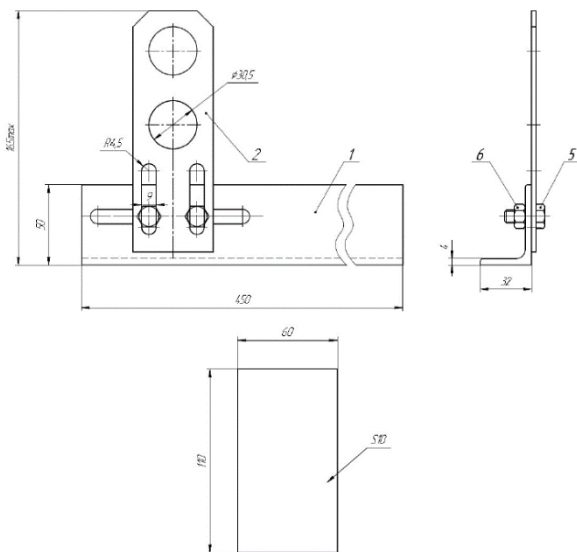

**Figure 18. Overall drawing of the support for VBI proximity sensor and trigger for DPS-140(I)**

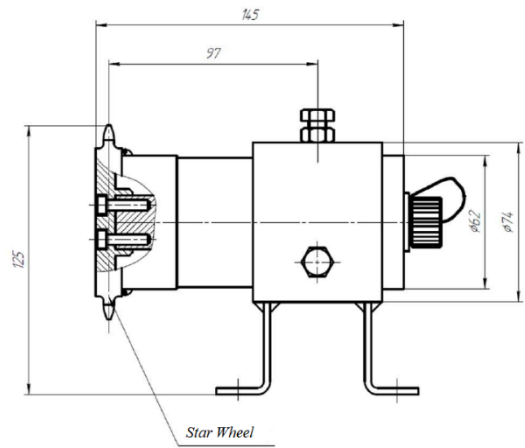

**Figure 19. Overall drawing of the DPS-140(A) with star wheel**

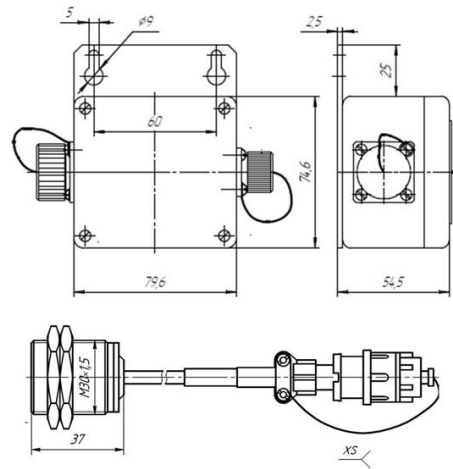

**Figure 20. Overall drawing of the DPS-140(I), Kit #1**

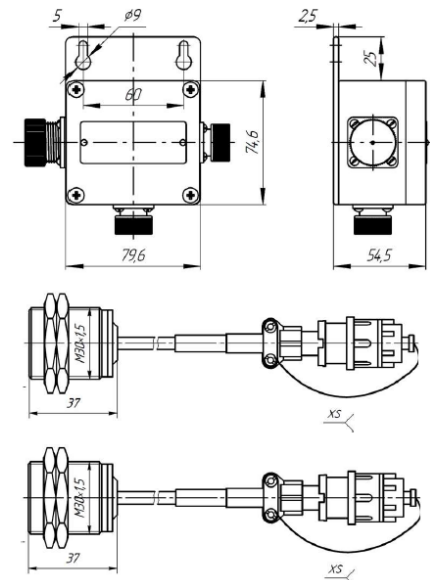

**Figure 21. Overall drawing of the DPS-140(I), Kit #2**

**RPE Petroline-A LLC**  
**Address: 53A Lermontova St., Naberezhnye Chelny,**  
**Republic of Tatarstan, Russian Federation, 423801**  
**Postal address: P.O. Box 23, 423801**  
**Phone/Fax: +7 (8552) 535-535, 71-74-61**  
[main@pla.ru](mailto:main@pla.ru), [www.pla.ru](http://www.pla.ru)